



NiQ motors

ebmpapst

the engineer's choice

	Page
Product information	80
Combination with axial blades	82

NiQ motors



Material/surface

- Housing: plastic (FDA compliant)

Mechanical data

- Direction of rotation: counter-clockwise viewed toward rotor
- Degree of protection: IP 54
- Insulation class: "H"
- Installation position: any
- Mode: continuous operation (S1)
- Mounting: maintenance-free ball bearings

Electrical data

- Motor protection: electronic
- Electrical hookup: cable for connection on motor side (see page 93)
- Protection class: II
- Additional functions: possible on request

Standards and approvals

- Conformity with standards: DIN EN 60335-1; DIN EN 60335-2-24; DIN EN 60335-2-89; CE; UL1004-1; UL1004-7; C22.2 No.77, C22.2 No.100, C22.2 No. 0.1;
- Approvals: VDE; UL; CSA; EAC

on Page 90	Accessories
on Page 108	Connection diagrams and technical features
on Page 120	Technical parameters and scope
More at	www.ebmpapst.com

Additional functions

NiQ reverse on start.

The NiQ reverse on start automatically runs in reverse for a preprogrammed time on starting. An important function for refrigeration devices, as it blows the accumulated dust out of the heat exchanger of the condenser - thus ensuring constant high cooling capacity.

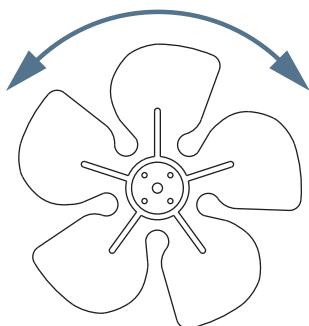

NiQ reverse on demand.

With the NiQ reverse on demand it is possible to define the time and duration of reverse operation as required. This means that the evaporator defrost cycle can be used to remove dust from the heat exchanger of the condenser for example.

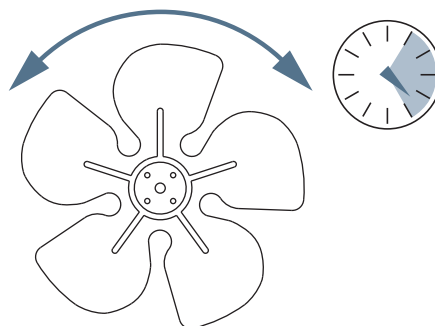

NiQ two speeds.

The particular feature of the NiQ two speeds is that it is supplied with two factory-programmed speed levels. This makes it possible to run the application in different day and night modes for even greater energy savings.

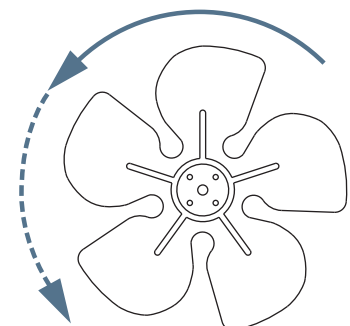

Type	Part number	Voltage VAC	Frequency Hz	Speed rpm	Max. input power W	Perm. ambient temp. °C	Weight kg	Conn. diagram	Maße (in mm)				
									A	B ⁽¹⁾	C ⁽²⁾	D	E
DE032BNKXX0S	5533201001	220-240	50/60	1300	9	-40.. +50	0.38	NiQ1)	49	74.0	79.0	30.5	43.5
	5533201004	100-240	50/60	1550	9	-40.. +50	0.38		49	74.0	79.0	30.5	43.5
DE032CNKXX0S	5533202007	220-240	50/60	1300	25	-40.. +50	0.46		49	82.0	87.0	30.5	43.5
	5533202011	100-240	50/60	1550	25	-40.. +50	0.46		49	-	87.0	30.5	43.5
DE032ENKXX0S	5533203006	220-240	50/60	1300	30	-40.. +50	0.62		54	91.5	96.5	38.5	43.5/51.5
	5533203007	100-240	50/60	1550	30	-40.. +50	0.62		54	-	96.5	38.5	43.5/51.5

Subject to change.

⁽¹⁾ Standard cover ⁽²⁾ Cover with blind holes

Engineering drawing

Dimensions in mm

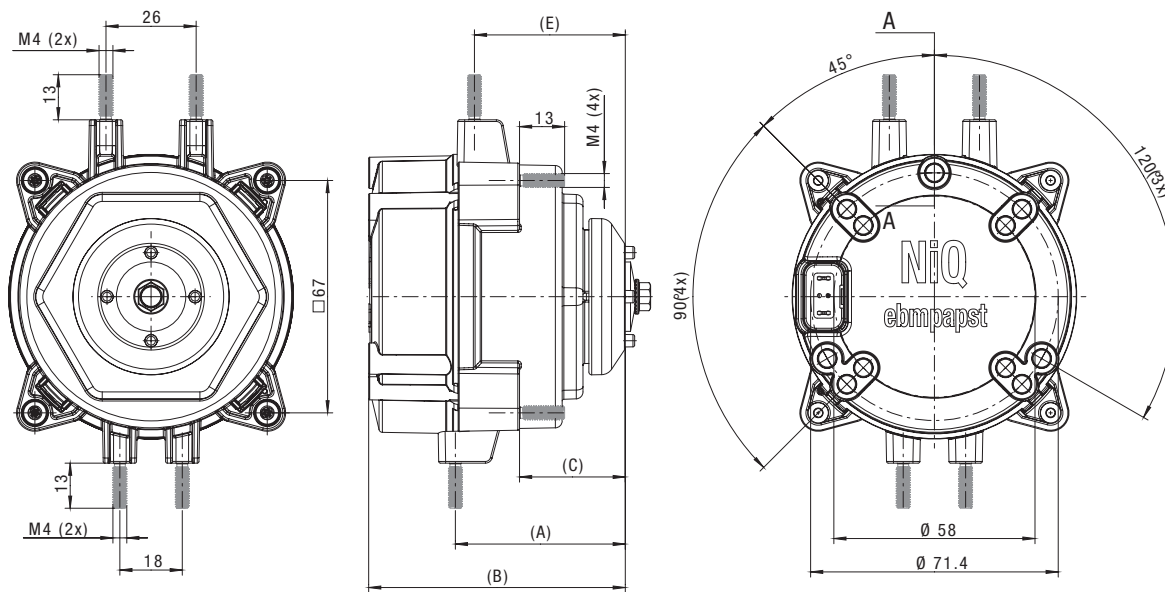

Cover with blind holes,
suitable for self-cutting screws

Standard cover, suitable for (M4)
threaded insert epL P/N 27450.19112

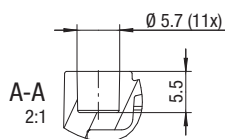
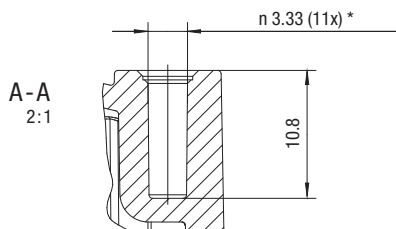

Side mounting pins are available on request.
Prepared for fan housing mounting.

NiQ: Combination with axial blades

Input power and airflow

NiQ motors

Motor	Axial blade diameter mm	Axial blade angle °	Family of curves	Input power W	Output power W	Air flow, free air at n = 1300 rpm m³/h
NiQ 3208 at 1300 rpm						
	154	22		2.6	1.7	165
	154	28	A	2.9	1.9	175
	154	34		3.6	2.3	215
	172	22		2.9	1.9	205
	172	28	B	4.1	2.7	265
	172	34		5.4	3.5	310
	200	22	C	4.7	3.1	335
	200	28		6.0	3.8	385
NiQ 3212 at 1300 rpm						
	200	22		3.9	2.6	330
	200	28	D	5.1	3.5	380
	200	34		6.7	4.6	460
	230	22		8.4	5.6	580
	230	28	E	12.7	8.4	690
	230	34		18.1	11.4	825
	254	22	F	11.2	7.6	735
NiQ 3224 at 1300 rpm						
	230	34	G	16.3	11.4	850
	254	22		10.8	7.6	750
	254	28	H	18.6	13.4	970
	254	34		26.2	18.8	1095
NiQ 3208 at 1550 rpm						
				3.5	1.8	195
			A	4.0	2.1	215
				5.0	2.6	365
				4.1	2.0	250
			B	6.0	3.2	325
				8.3	4.7	385
			C	-	-	-
				-	-	-
NiQ 3212 at 1550 rpm						
				6.0	3.8	400
			D	7.7	5.0	470
				11.0	7.3	555
				14.0	9.6	675
			E	20.9	13.2	820
				-	-	-
			F	-	-	-
				-	-	-
NiQ 3224 at 1550 rpm						
			G	26.5	19.2	1000
				17.2	12.2	920
			H	30.5	21.1	1160
				-	-	-

All values determined for air flow direction "V". Power consumption and output power determined without fan housing. Air flow determined with fan housing.

NiQ: Combination with axial blades

Air performance curves determined in fan housing, at a constant speed of 1300 rpm.

Family of air performance curves at 1300 rpm

NiQ 3208 with axial blades Ø 154 mm

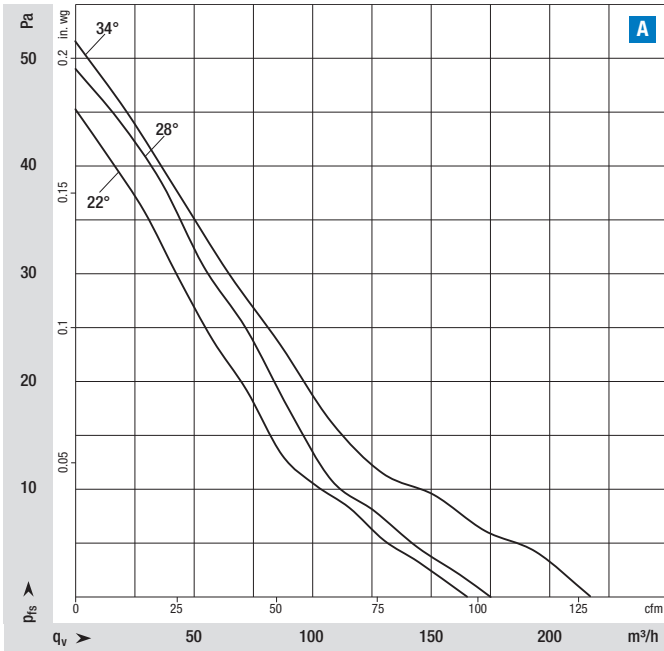

NiQ 3208 with axial blades Ø 172 mm

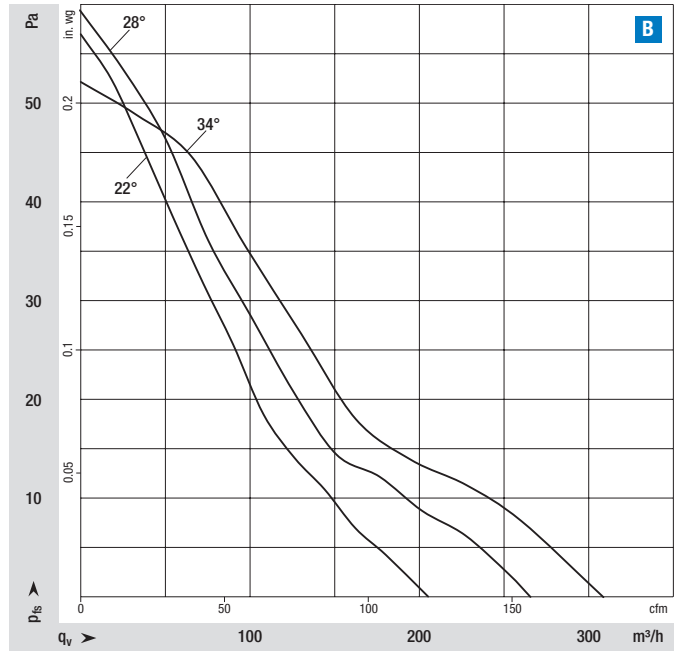

NiQ 3208 with axial blades Ø 200 mm

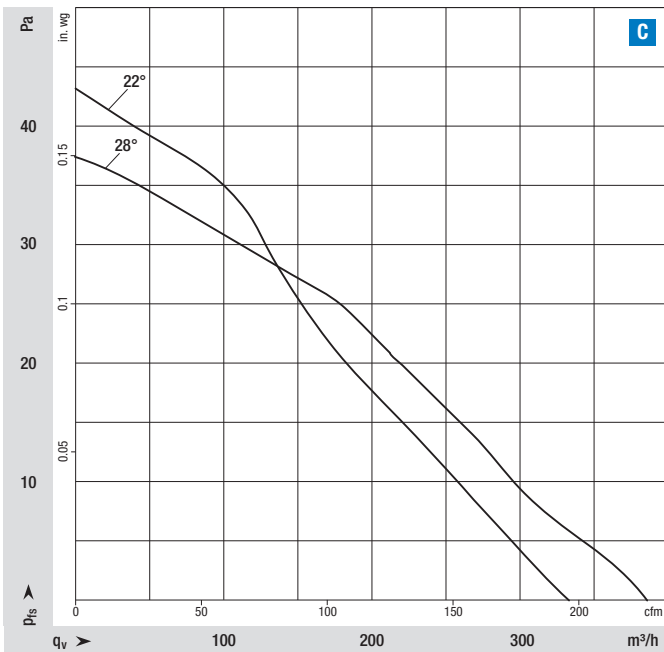

NiQ: Combination with axial blades

Air performance curves determined in fan housing, at a constant speed of 1550 rpm.

Family of air performance curves at 1550 rpm

NiQ 3208 with axial blades Ø 154 mm

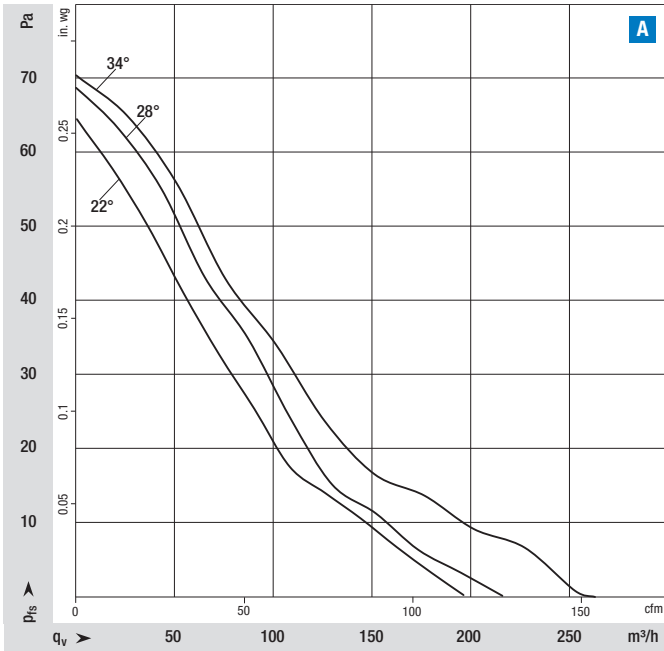

NiQ 3208 with axial blades Ø 172 mm

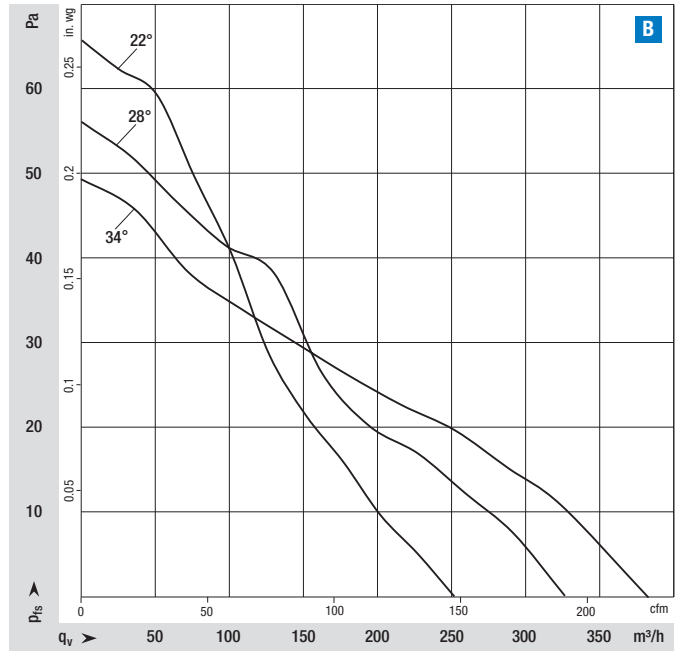

NiQ 3208 with axial blades Ø 200 mm

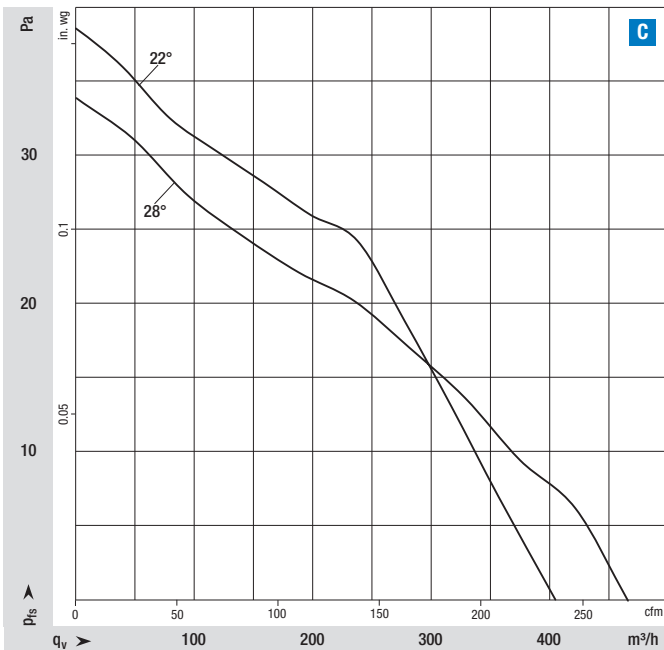

NiQ: Combination with axial blades

Air performance curves determined in fan housing, at a constant speed of 1300 rpm.

Family of air performance curves at 1300 rpm

NiQ 3212 with axial blades Ø 200 mm

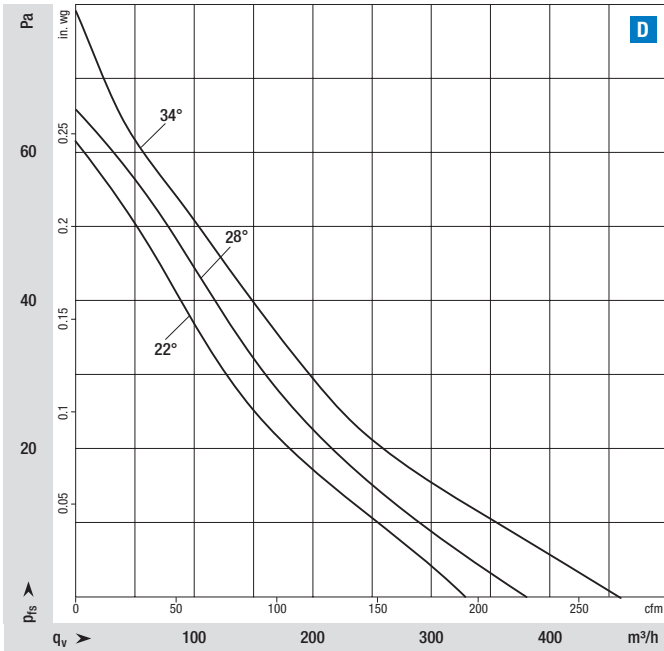

NiQ 3212 with axial blades Ø 230 mm

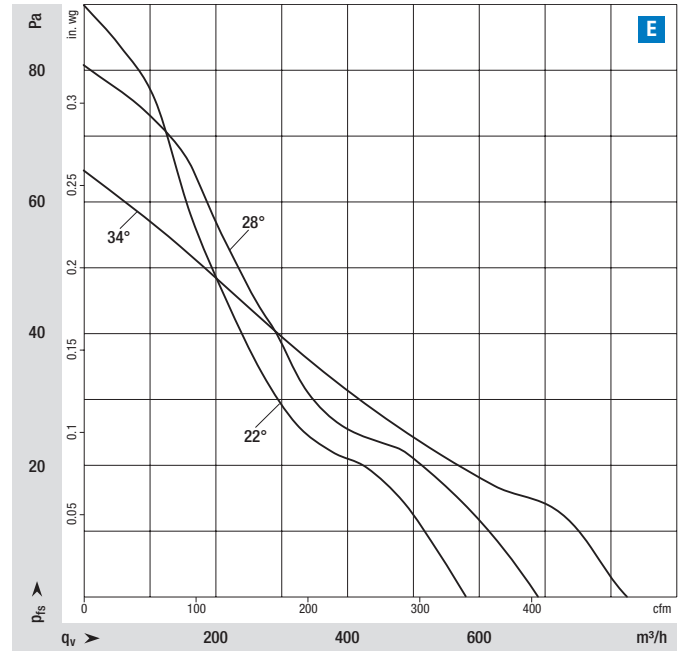

NiQ 3212 with axial blades Ø 254 mm

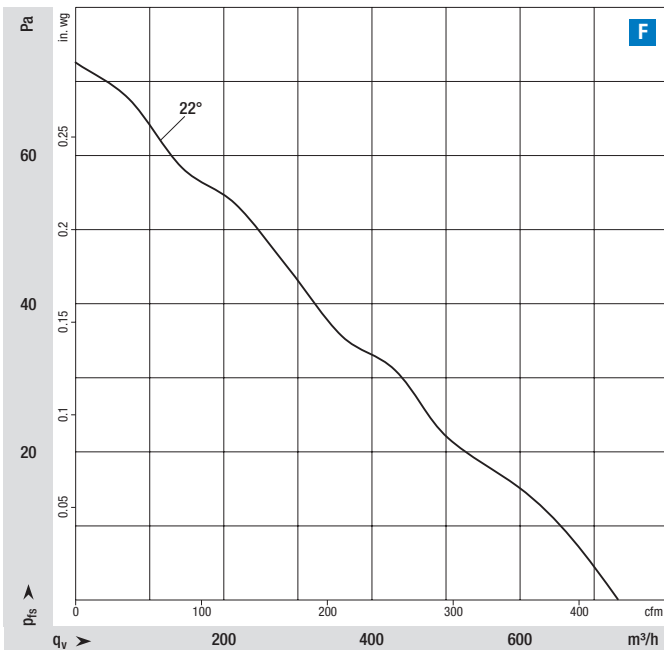

NiQ: Combination with axial blades

Air performance curves determined in fan housing, at a constant speed of 1550 rpm.

Family of air performance curves at 1550 rpm

NiQ 3212 with axial blades Ø 200 mm

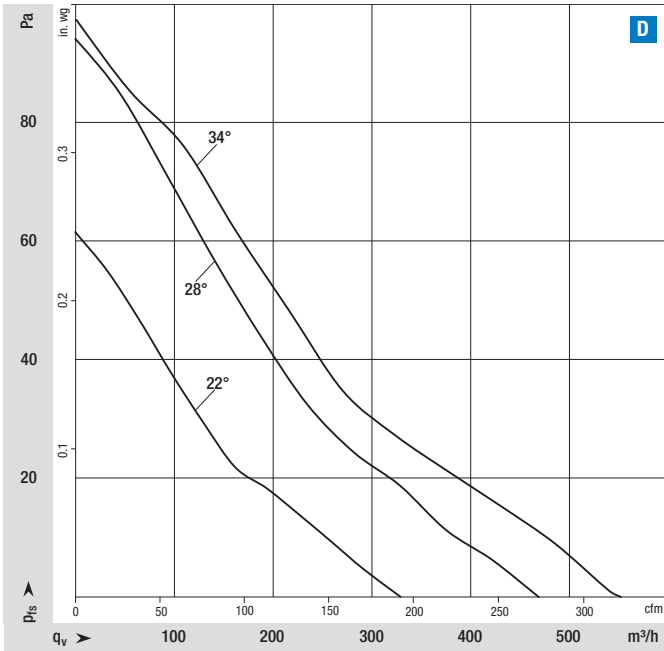

NiQ 3212 with axial blades Ø 230 mm

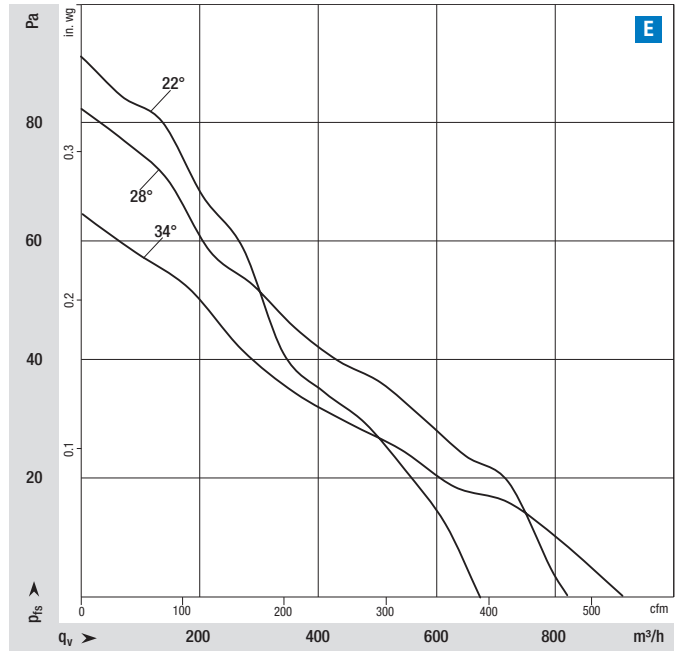

NiQ 3212 with axial blades Ø 254 mm

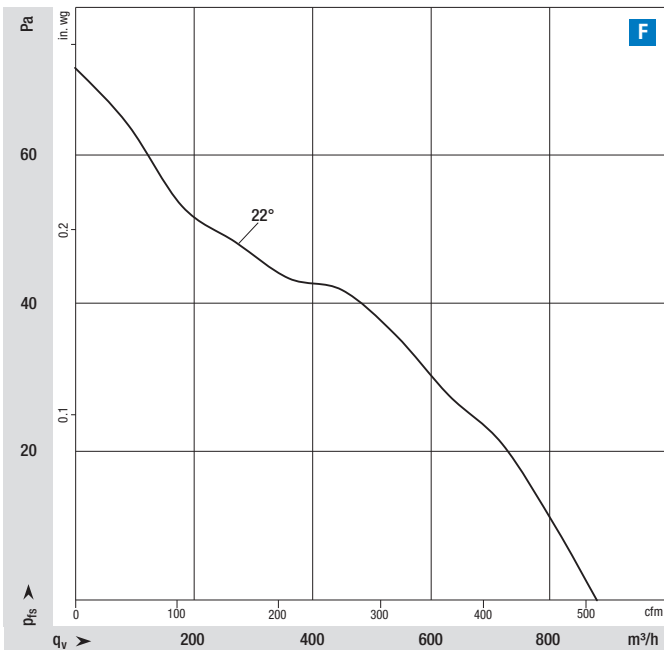

NiQ: Combination with axial blades

Air performance curves determined in fan housing, at a constant speed of 1300 rpm.

Family of air performance curves at 1300 rpm

NiQ 3224 with axial blades Ø 230 mm

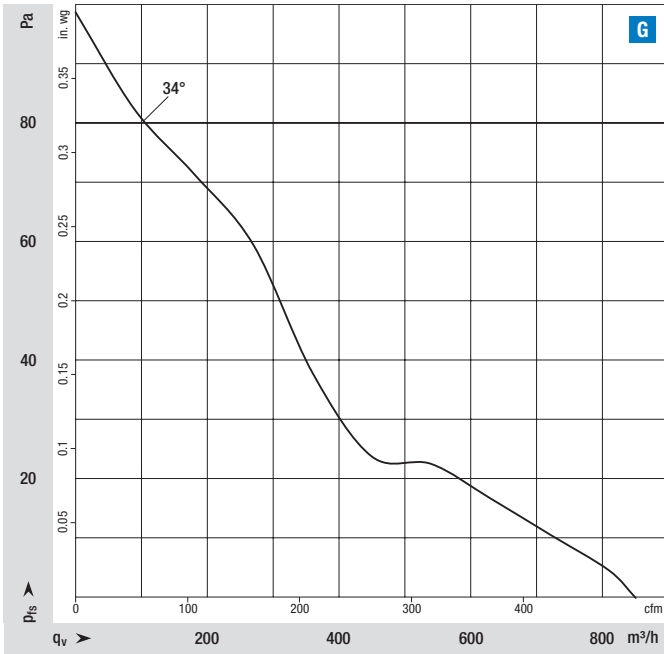

NiQ 3224 with axial blades Ø 254 mm

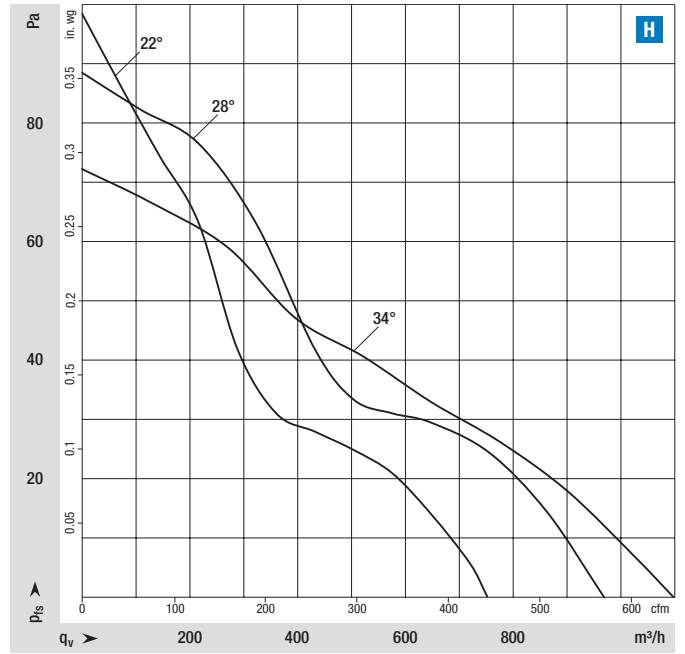

NiQ: Combination with axial blades

Air performance curves determined in fan housing, at a constant speed of 1550 rpm.

Family of air performance curves at 1550 rpm

NiQ 3224 with axial blades Ø 230 mm

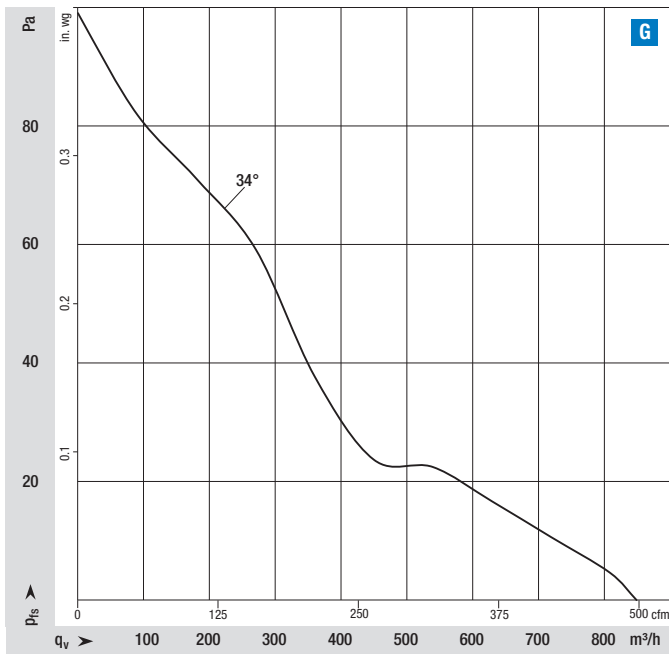

NiQ 3224 with axial blades Ø 254 mm

