

## SC15MNX MBP Compressor R290 220-240V 50Hz

### General

Code number	104H8575
Approvals	EN 60335-2-34,CCC
Compressors on pallet	80

### Application

Application	MBP		
Frequency	Hz	50	60
Evaporating temperature	°C	-35 to 10	-
Voltage range	V	198 - 254	-
Max. condensing temperature continuous (short)	°C	55 (65)	-
Max. winding temperature continuous (short)	°C	125 (135)	-

### Cooling requirements

Frequency	Hz	50			60		
Application		LBP	MBP	HBP	LBP	MBP	HBP
32°C		-	F <sub>2</sub>	-	-	-	-
38°C		-	F <sub>2</sub>	-	-	-	-
43°C		-	F <sub>2</sub>	-	-	-	-
Remarks on application:							

### Motor

Motor type	CSIR		
LRA (rated after 4 sec. UL984), HST   LST	A	18.6	-
Cut in Current, HST   LST	A	18.6	-
Resistance, main   start winding (25°C)	Ω	3.7	14.1

### Design

Displacement	cm <sup>3</sup>	15.28
Oil quantity (type)	cm <sup>3</sup>	600 (polyolester)
Maximum refrigerant charge	g	150
Free gas volume in compressor	cm <sup>3</sup>	1510
Weight without electrical equipment	kg	13.5

### Dimensions

Height	mm	A	219
		B	213
		B1	193
		B2	110
Suction connector	location/I.D. mm   angle	C	8.2   37°
	material   comment		Copper   Rubber plug
Process connector	location/I.D. mm   angle	D	6.2   37°
	material   comment		Copper   Rubber plug
Discharge connector	location/I.D. mm   angle	E	6.2   37°
	material   comment		Copper   Rubber plug
Oil cooler connector	location/I.D. mm   angle	F	-
	material   comment		-
Connector tolerance	I.D. mm		±0.09
Remarks:			

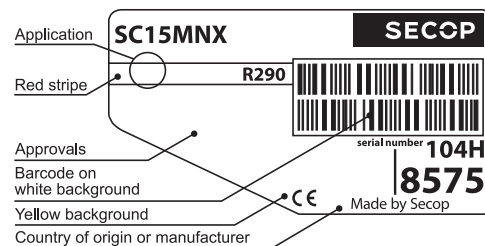

Yellow warning label

- S = Static cooling normally sufficient
- O = Oil cooling
- F<sub>1</sub> = Fan cooling 1.5 m/s  
(compressor compartment temperature equal to ambient temperature)
- F<sub>2</sub> = Fan cooling 3.0 m/s necessary
- SG = Suction gas cooling normally sufficient
- = not applicable in this area

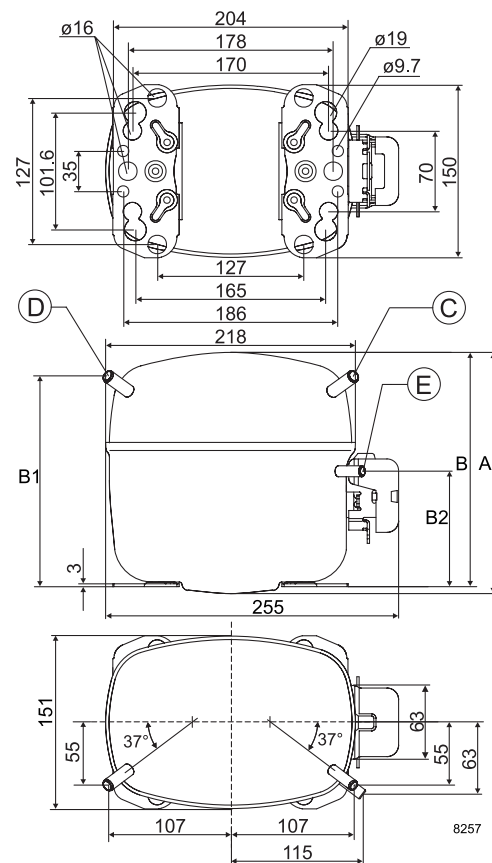

**EN 12900 MBP**

220V, 50Hz, fan cooling F<sub>2</sub>

Evap. temp. in °C	-45	-40	-35	-30	-25	-23.3	-20	-15	-10	-6.7	-5	0	5	7.2	10	15	20
Capacity in W			313	428	561	611	715	893	1098	1249	1332	1598	1900	2044	2239		
Power cons. in W			80	259	392	428	487	553	597	618	627	652	678	692	714		
Current cons. in A			2.75	2.95	3.15	3.21	3.33	3.50	3.65	3.75	3.80	3.93	4.05	4.10	4.16		
COP in W/W			3.89	1.65	1.43	1.43	1.47	1.62	1.84	2.02	2.12	2.45	2.80	2.95	3.13		

**ASHRAE HBP/MBP**

220V, 50Hz, fan cooling F<sub>2</sub>

Evap. temp. in °C	-45	-40	-35	-30	-25	-23.3	-20	-15	-10	-6.7	-5	0	5	7.2	10	15	20
Capacity in W			329	440	564	610	705	866	1050	1185	1260	1499	1772	1901	2080		
Power cons. in W			88	274	416	456	522	599	656	686	700	739	781	803	835		
Current cons. in A			2.67	2.92	3.17	3.25	3.40	3.62	3.83	3.96	4.02	4.21	4.38	4.45	4.54		
COP in W/W			3.75	1.60	1.35	1.34	1.35	1.44	1.60	1.73	1.80	2.03	2.27	2.37	2.49		

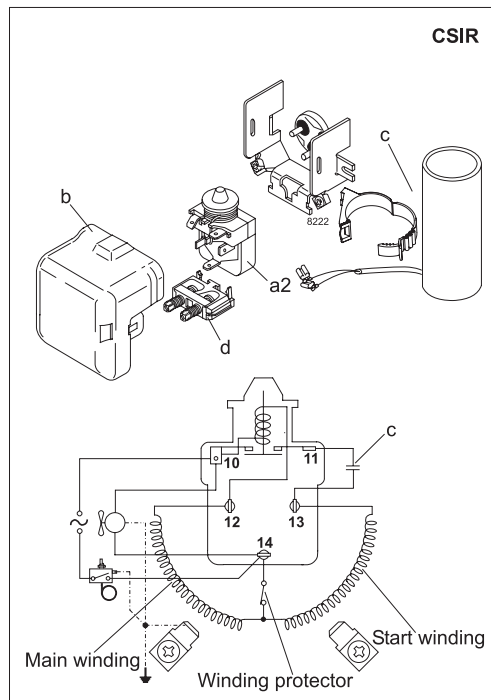

Accessories for	SC15MNX	Figure	Code number	Test conditions	EN 12900 MBP	ASHRAE HBP/MBP
PTC starting device	6.3 mm spade connectors	-	-	Condensing temperature	45°C	54.4°C
	4.8 mm spade connectors			Ambient temperature	32°C	35°C
Starting relay	6.3 mm spade connectors	a2	117U7019	Suction gas temperature	20°C	35°C
Cover		b	103N2008	Liquid temperature	no subcooling	46.1°C
Start. capacitor 80 µF	6.3 mm spade connectors	c	117U5017			
Cord relief		d	103N1004			
Protection screen for PTC		-	-			
				<b>Mounting accessories</b>	<b>Code number</b>	
				Bolt joint for one comp.	Ø: 16 mm	118-1917
				Bolt joint in quantities	Ø: 16 mm	118-1918
				Snap-on in quantities	Ø: 16 mm	118-1919

Nidec GA Compressors accepts no responsibility for possible errors in catalogs, brochures, and other printed material. Nidec GA Compressors reserves the right to alter its products without notice. This also applies to products already on order provided that such alterations can be made without consequential changes being necessary to specifications already agreed. All trademarks in this material are the property of the respective companies. Secop and the Secop logotype are trademarks of Nidec Global Appliance Germany GmbH. All rights reserved. [www.secop.com](http://www.secop.com)