

Datasheet

SC21G Universal Compressor

R134a 220-240V 50/60Hz

General

Code number	104G8140
Approvals	EN 60335-2-34
Compressors on pallet	80

Application

Application	LBP/HBP	LBP
Frequency	Hz 50	60
Evaporating temperature	°C -25 to 15	-25 to -5
Voltage range	V 187 - 254	198 - 254
Max. condensing temperature continuous (short)	°C 60 (70)	60 (70)
Max. winding temperature continuous (short)	°C 125 (135)	125 (135)

Cooling requirements

Frequency	Hz	50			60		
		LBP	MBP	HBP	LBP	MBP	HBP
32°C		F ₂	F ₂	F ₂	F ₂	-	-
38°C		F ₂	F ₂	F ₂	F ₂	-	-
43°C		F ₂	F ₂	F ₂	F ₂	-	-

Remarks on application:

Not applicable below -25°C evaporating temp. in 43°C ambient temperature above 240V. HBP at 198 - 254V 50Hz only.

Motor

Motor type	CSR		
LRA (rated after 4 sec. UL984), HST LST	A	21.8	-
Cut in Current, HST LST	A	21.8	-
Resistance, main start winding (25°C)	Ω	3.5	12.1

Design

Displacement	cm ³	20.95
Oil quantity (type)	cm ³	550 (polyolester)
Maximum refrigerant charge	g	1300
Free gas volume in compressor	cm ³	1460
Weight without electrical equipment	kg	13.5

Dimensions

Height	mm	A	219
		B	213
		B1	193
		B2	110
Suction connector	location/I.D. mm angle	C	10.2 37°
	material comment	Cu-plated steel Al cap	
Process connector	location/I.D. mm angle	D	6.2 37°
	material comment	Cu-plated steel Al cap	
Discharge connector	location/I.D. mm angle	E	6.2 37°
	material comment	Cu-plated steel Al cap	
Oil cooler connector	location/I.D. mm angle	F	-
	material comment	-	
Connector tolerance	I.D. mm	±0.09	
Remarks:			

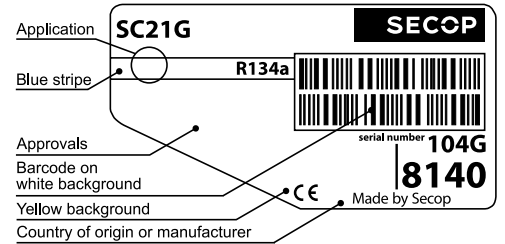

- S = Static cooling normally sufficient
- O = Oil cooling
- F₁ = Fan cooling 1.5 m/s (compressor compartment temperature equal to ambient temperature)
- F₂ = Fan cooling 3.0 m/s necessary
- SG = Suction gas cooling normally sufficient
- = not applicable in this area

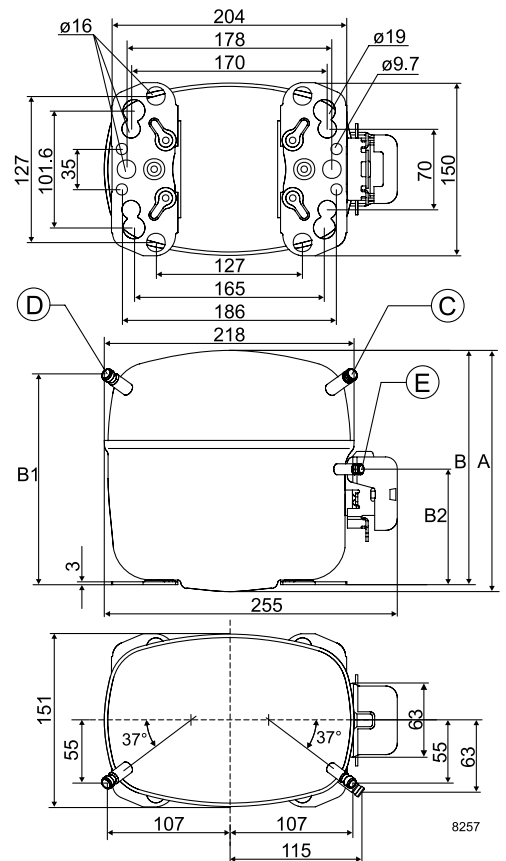

EN 12900 Household

220V, 50Hz, fan cooling F₂

Evap. temp. in °C	-45	-40	-35	-30	-25	-23.3	-20	-15	-10	-6.7	-5	0	5	7.2	10	15	20
Capacity in W					333	370	453	606	792	934	1012	1268	1560	1700	1889	2256	
Power cons. in W					382	404	445	509	575	620	643	714	789	823	868	953	
Current cons. in A					2.28	2.34	2.48	2.71	2.96	3.14	3.24	3.54	3.87	4.02	4.22	4.60	
COP in W/W					0.87	0.92	1.02	1.19	1.38	1.51	1.58	1.78	1.98	2.07	2.18	2.37	

ASHRAE LBP

220V, 50Hz, fan cooling F₂

Evap. temp. in °C	-45	-40	-35	-30	-25	-23.3	-20	-15	-10	-6.7	-5	0	5	7.2	10	15	20
Capacity in W					410	456	558	746	977	1156	1250	1568	1931	2106	2343	2803	
Power cons. in W					382	404	445	509	575	620	643	714	789	823	868	953	
Current cons. in A					2.28	2.34	2.48	2.71	2.96	3.14	3.24	3.54	3.87	4.02	4.22	4.60	
COP in W/W					1.07	1.13	1.25	1.47	1.70	1.86	1.95	2.20	2.45	2.56	2.70	2.94	

EN 12900 Household

230V, 60Hz, fan cooling F₂

Evap. temp. in °C	-45	-40	-35	-30	-25	-23.3	-20	-15	-10	-6.7	-5	0	5	7.2	10	15	20
Capacity in W					311	364	476	671	903	1078	1175						
Power cons. in W					374	406	466	553	638	693	721						
Current cons. in A					1.82	1.95	2.21	2.58	2.95	3.19	3.31						
COP in W/W					0.83	0.90	1.02	1.21	1.42	1.56	1.63						

ASHRAE LBP

230V, 60Hz, fan cooling F₂

Evap. temp. in °C	-45	-40	-35	-30	-25	-23.3	-20	-15	-10	-6.7	-5	0	5	7.2	10	15	20
Capacity in W					392	457	595	835	1121	1336	1456						
Power cons. in W					378	409	468	554	637	692	720						
Current cons. in A					1.83	1.96	2.21	2.58	2.94	3.18	3.29						
COP in W/W					1.04	1.12	1.27	1.51	1.76	1.93	2.02						

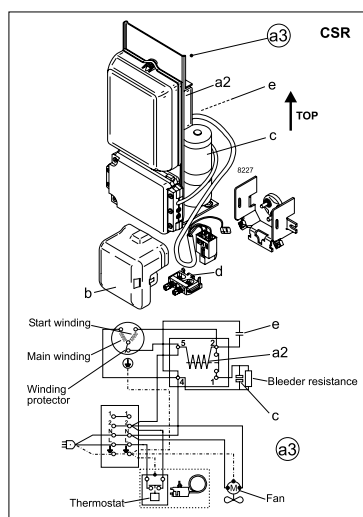

Accessories for SC21G	Figure	Code number
Starting device	a3	117-7029
		117-7032
Cover	b	103N2009
Starting relay	a2	Components of starting device
Starting capacitor	c	
Run capacitor	e	
Cord relief	d	103N1004

Test conditions	EN 12900/CECOMAF	ASHRAE LBP
Condensing temperature	55°C	55°C
Ambient temperature	32°C	32°C
Suction gas temperature	32°C	32°C
Liquid temperature	no subcooling	32°C

Mounting accessories	Code number	
Bolt joint for one comp.	Ø: 16 mm	118-1917
Bolt joint in quantities	Ø: 16 mm	118-1918
Snap-on in quantities	Ø: 16 mm	118-1919

Danfoss can accept no responsibility for possible errors in catalogues, brochures and other printed material. Danfoss reserves the right to alter its products without notice. This also applies to products already on order provided that such alterations can be made without consequential changes being necessary in specifications already agreed. All trademarks in this material are property of the respective companies. Danfoss and the Danfoss logotype are trademarks of Danfoss A/S. All rights reserved.