



CODE: 4-010-139
TYPE: 3RGB 50-30/ 1

230V ~ 50Hz 0.53A
40/114 W TH.PROT. INS.CL.B
1100 Rpm

ROTATION ←

DATA



WHITE	COMMON
BLACK	MAX-1
BLUE	MID-2
RED	MIN-3
M	
YELLOW	
YELLOW	C
YELLOW/GREEN	

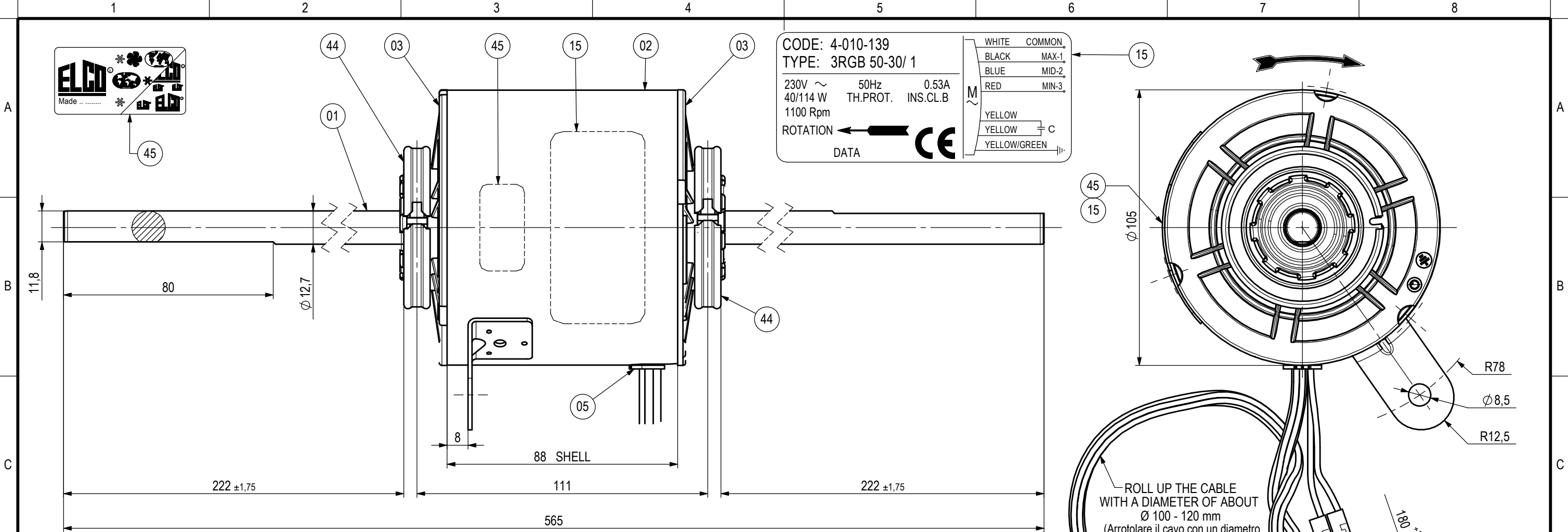

PARTS SUPPLY LOOSE (Particolari finiti a parte)
INSERT THESE PARTS IN THE SAME BOX OF MOTORS
WHERE THERE IS THE SHAFT

(Inserire questi componenti nella stessa scatola dei motori, nella sede dove risiede l'albero)

CLASS "B" MOTOR - SLEEVE BEARING MANUFACTURED (Motore classe "B" - Esecuzione a Bronzine)	
AXIAL CLEARANCE (Gioco Assiale)	1,0 - 3,5
SHELL (Fascia)	CLOSED (Chiusa)
END SHIELD - CABLE SIDE (Coperchio lato cavi)	CLOSED (Chiuso)
END SHIELD - OPPOSITE CABLE SIDE (Copechio lato opposto cavi)	CLOSED (Chiuso)
ASSEMBLY SPECIFICATION No. (Normativa per note di montaggio)	EL.UN.0009
MECHANICAL SPECIFICATION No. (Normativa per note di controllo meccanico)	EL.CM.0002
ELECTRICAL SPECIFICATION No. (Prescrizione per controllo elettrico)	M.771/2

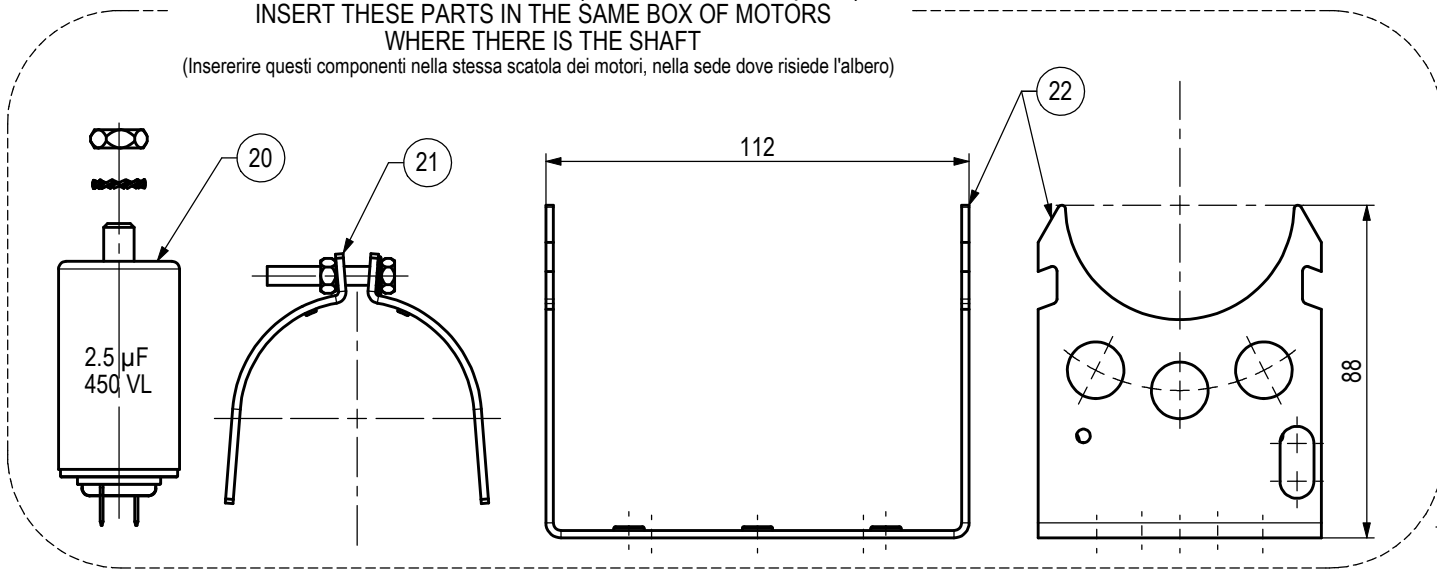

ROLL UP THE CABLE WITH A DIAMETER OF ABOUT $\phi 100 - 120$ mm
(Arrotolare il cavo con un diametro di circa $\phi 100 - 120$ mm)

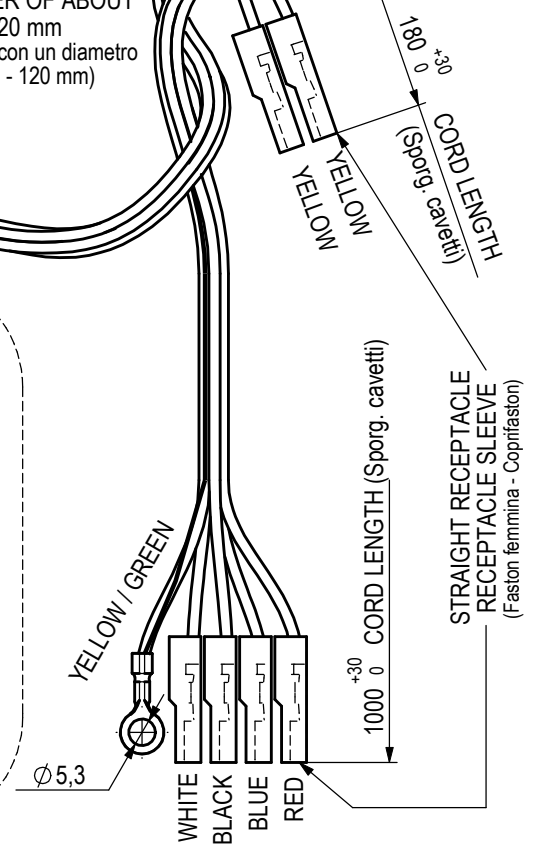

Rel.	Date	Description	Executor signature	Checked
E	04-04-11	DELETED NYLON BOOTLACE: ITEM 24. (Tolto laccio Nylon: pallinatura 24)	RdM 11/0007 A.T.	D.Riboldi T.Sirtori
D	17-10-06	Aggiunto cavo di terra con capocorda occhiello, era con Stg. Ammortizzatore c/lamella di massa.	RdM 06/0042 A.T.	A.Zoncada T.Sirtori
C	12-09-03	Trasferito disegno su sistema CAD.		A.Franzolin T.Sirtori
B	04-07-02	Variato Prescrizione di collaudo, era M.771/1.		
A	27-04-92	Unito Targhetta freccia in una unica, erano separate.		

	Drawn Baldi Date 08/05/84 Check --- Scale ---	Treatment Material	A3
	SINGLE PHASE MOTOR 3RGB 50-30/ 1 Motore Monofase	Weight gr. Ref. No	Release E
		4-010-139	